

DULLABH COMMERCIALS

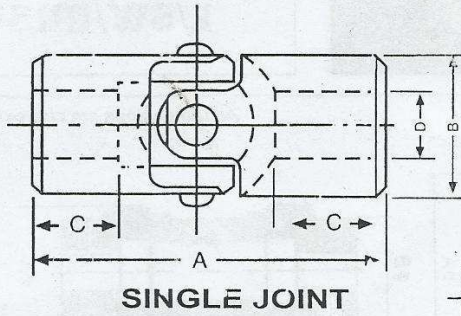

Universal Joint Coupling

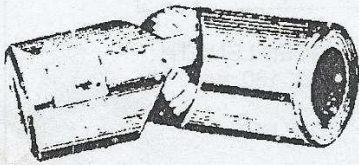
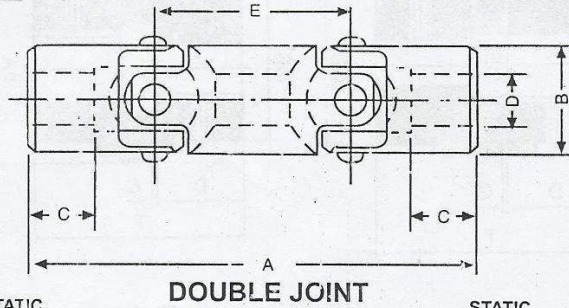

STATIC
BREAKING
TORQUE

STATIC
BREAKING
TORQUE

SERIES NO.	B	A	BORE SIZE		C	N.m.	SERI. NO.	B	A	BORE SIZE		C	E	N.m.
			STANDARD	WITH KEY WAY						STANDARD	WITH KEY WAY			
SJ 1	9.5	44	6	-	13	2'	DJ 1	13	71.5	8		15	21.5	44
SJ 2	13	50	8	-	15	44	DJ 2	16	81	10	7.5	16	25	75
SJ 3	16	58	10	7.5	17	75	DJ 3	19	91	12	8.5	19	27	89
SJ 4	19	64	12	8.5	19	89	DJ 4	22.5	111	14	11	21	35	135
SJ 5	22.5	76	14	11	21	135	DJ 5	22.5	122	16	12	25	36	193
SJ 6	25.5	86	16	12	25	193	DJ 6	29	133	18	14	26	43	331
SJ 7	29	90	18	14	26	331	DJ 7	32	143	20/22	16	26.5	48	600
SJ 8	32	95	20/22	16	26.5	600	DJ 8	38.5	162	25	19	30	54	910
SJ 9	38.5	108	25	19	30	910	DJ 9	44.5	194	30	22.5	34.5	67	1230
SJ 10	44.5	127	30	22.5	34.5	1230	DJ 10	51	218	35	27.5	38	78	1790
SJ 11	51	140	35	27.5	38	1790	DJ 11	57.5	245	40	32	47.5	80	2850
SJ 12	57.5	165	50	32	47.5	2860	DJ 12	63.5	267	45	36.5	50	89	3810
SJ 13	63.5	178	45	36.5	50	3810	DJ 13	76.5	318	50	44.5	56	96	7510
SJ 14	76.5	222	50	44.5	66	7510	DJ 14	89	365	65	53	78	111	11010
SJ 15	89	254	65	53	78.5	11010	DJ 15	102	410	70	62	94	118	15850
SJ 16	102	292	70	62	94	15850	-	-	-	-	-	-	-	-

ALL DIMENSION IN MM

INTRODUCTION :-

Universal Joints proved a simple & economic method of connecting two shafts whose axes are inclined at an angle. They are also used when the angle varies during rotation eliminating the need for the complicated & expensive mechanisms usually associated with this type of application.

LUBRICATION :-

For both intermittent & continuously rated joints where constant lubrication (such as an oil bath) is not available joint covers suitable for grease packing are recommended.